

RX02 Emulator Interface

NOTE: Interface symbols with alphabetic designations indicate connections to the PDP interface. Numeric designations indicate connections to the PC interface. Signal names with PC before the level indicate signals attached to the PC.

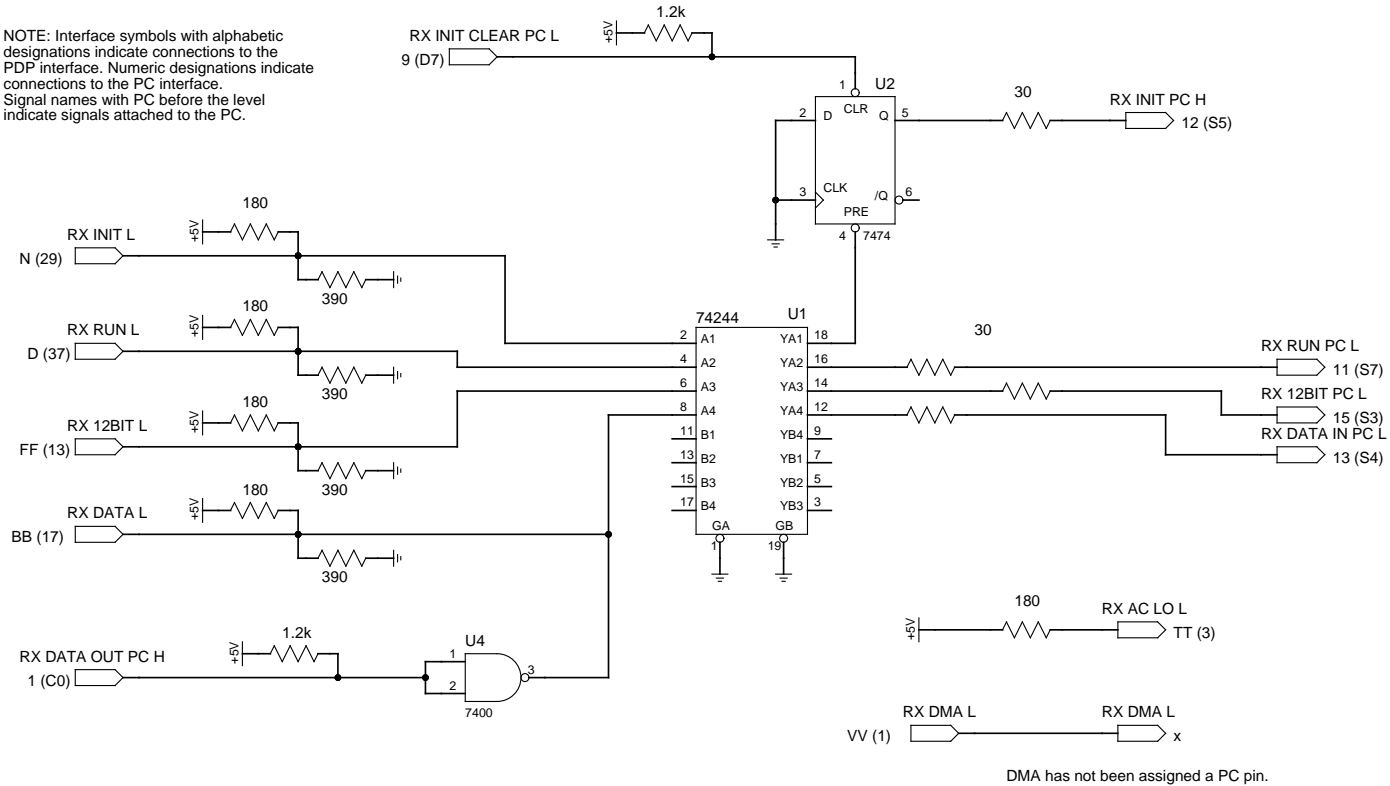

IC CHART

- U1 74LS244
- U2 74LS74
- U3 74LS38
- U4 74LS38

Symbol descriptions may not match actual chip used.

design by: Charles H Dickman

date: 06/11/2003

rev: B

